

SPECIFICATION FOR APPROVED 樣品承認書

2023
NEW

機構圖 Shape and Dimensions(mm) :

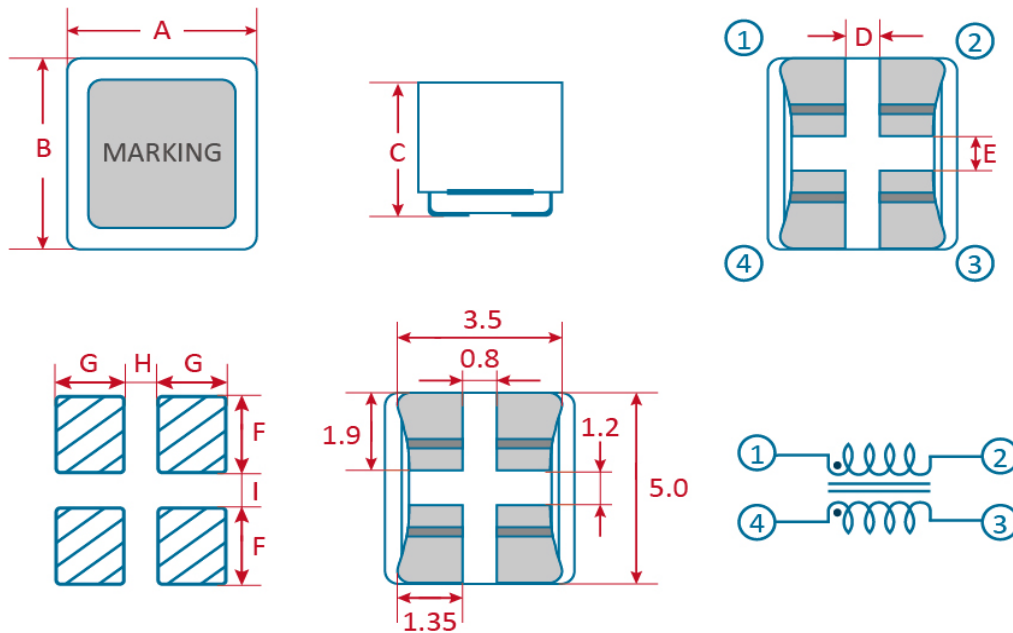

Item	A	B	C	D	E	F	G	H	I
CMB5040	4.8 ± 0.2	5.0 ± 0.2	4.5 Max.	0.8 Typ.	1.0 Typ.	2.3 Ref.	1.6 Ref.	0.8 Ref.	1.0 Ref.

印字Marking : (印字顏色因生產設備而有所差異)

CMB5040

Part No.	Commom Mode Impedance(Ω)	DCR(Ω)	Rated Current(A)	IR(MΩ)	Rated Voltage(V)
	Typ.	±40%	Max.	Min.	Max.
CMB5040-191	190	0.009	6.0	10	60
CMB5040-351	350	0.012	5.5	10	60
CMB5040-501	500	0.014	5.0	10	60
CMB5040-102	1000	0.016	4.5	10	60

Ordering information

CMB5040 - 191

- (1) (2)
 (1) Type : COMMON MODE CHOKE
 (2) Size : 5040 is size
 (3) Packaging style : Taping Reel
 (4) Commom Mode Impedance(Ω) : :191 for 190Ω, 351 for 350Ω...

Characteristics

- Rated Current : DC current (A)that will cause an approximate ΔT of 40°C (Maximum)
- Operating temperature range : -40°C to +125°C

Test equipment

- Test Frequency : 100MHz ,0.1 Vrms.



CMB5040-191

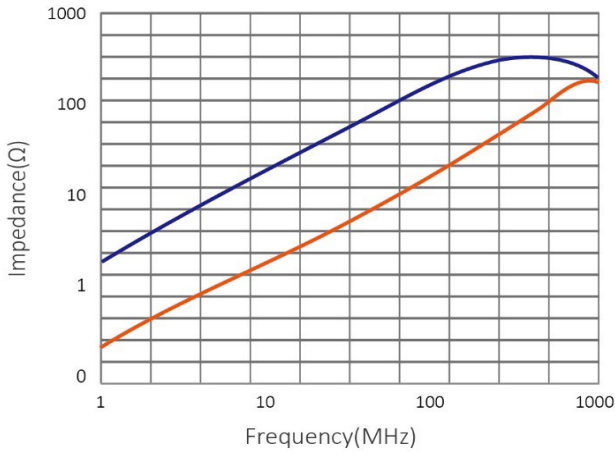

CMB5040-351

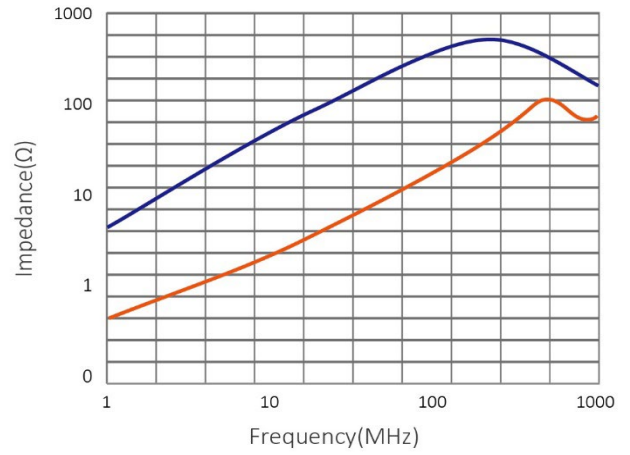

CMB5040-501

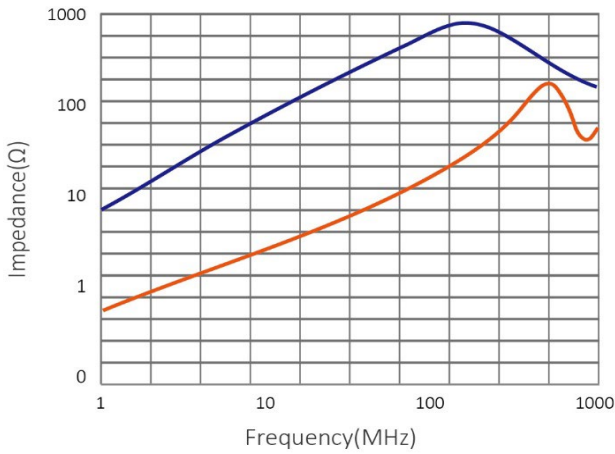

CMB5040-102

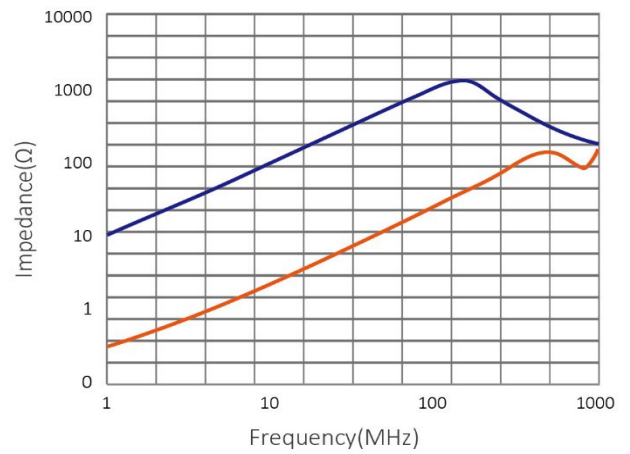

TAPE AND REEL SPECIFICATIONS

