

SPECIFICATION FOR APPROVED
樣品承認書

2023
 NEW

料號 P/N : LFT4127-2MH-16A-B

機構圖 Shape and Dimensions(mm) :

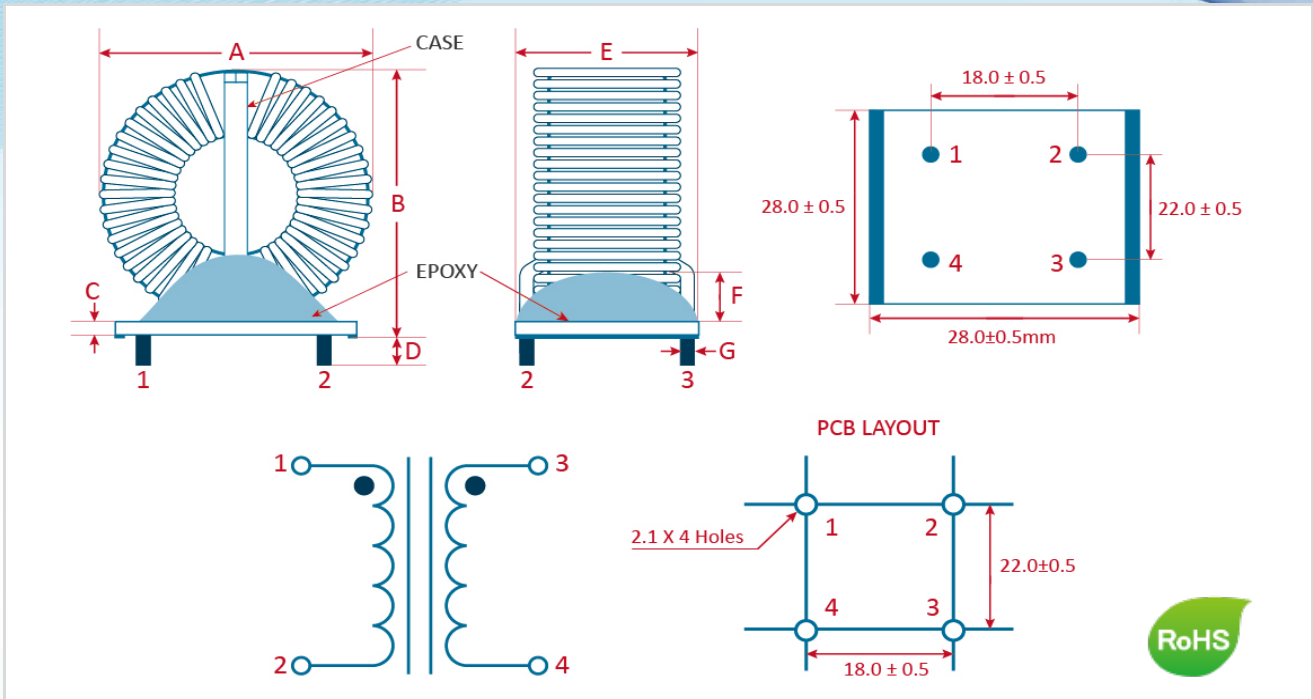

Item	A	B	C	D	E	F	G
規格 Spec.	41.5 Max.	40.0 Max.	1.6 ± 0.2	3.8 ± 0.5	27.0 Max.	6.0 Min.	1.8+0.1/-0.2
實測值 Typ.							

電特性要求 Electrical Characteristics :

Item	規格 Specifications	定義Note
L1-2=L3-4	2.0 mH MIN.	
Test Freq	@1kHz / 0.25V	
DCR1-2=DCR3-4	22mΩ Max.	
R.Current	16A Max.	
HI-POT TEST	COILS -- COILS 1500VAC / 3mA / 1sec	
I.R TEST	COILS -- COILS 100MΩ MIN	
WIRE	1.80mm 1PEWH	
TURNS	16.5 Ts (REF.) X 2	
Oper. Temp	-25°C to +100°C	