

SPECIFICATION FOR APPROVED
樣品承認書

2023
 NEW

料號 P/N : SPC10D48MT100-M

機構圖 Shape and Dimensions(mm) :

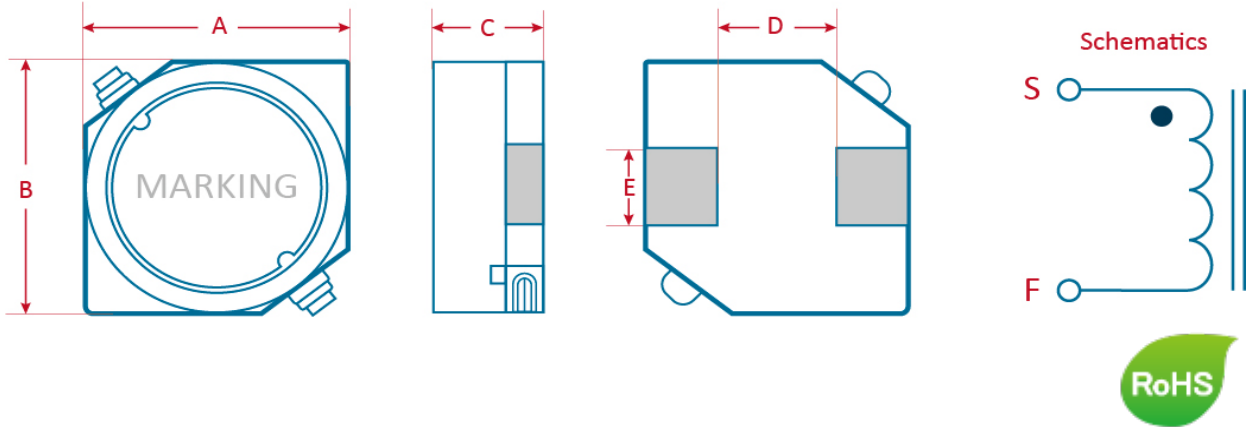

Item	A	B	C	D	E
規格 Spec.	10.5±0.5	10.5±0.5	5.0 Max.	6.0 REF.	2.0 REF.
實測值 Typ.					

印字Marking : 100 (印字顏色因生產設備而有所差異)

電特性要求 Electrical Characteristics :

Item	規格 Specifications	定義Note
L	10uH ±20%	
Test Freq	@1KHz / 0.25V	
DCR	0.04Ω Max.	
IDC	3.50A Max.	
Oper. Temp	-40°C to +125°C	

註 : IDC: Based on Inductance decrease 35%

TAPE AND REEL SPECIFICATIONS

