

SPECIFICATION FOR APPROVED  
**樣品承認書**

2022  
 NEW

料號 P/N : LFT2208-302U-5A

機構圖 Shape and Dimensions(mm) :

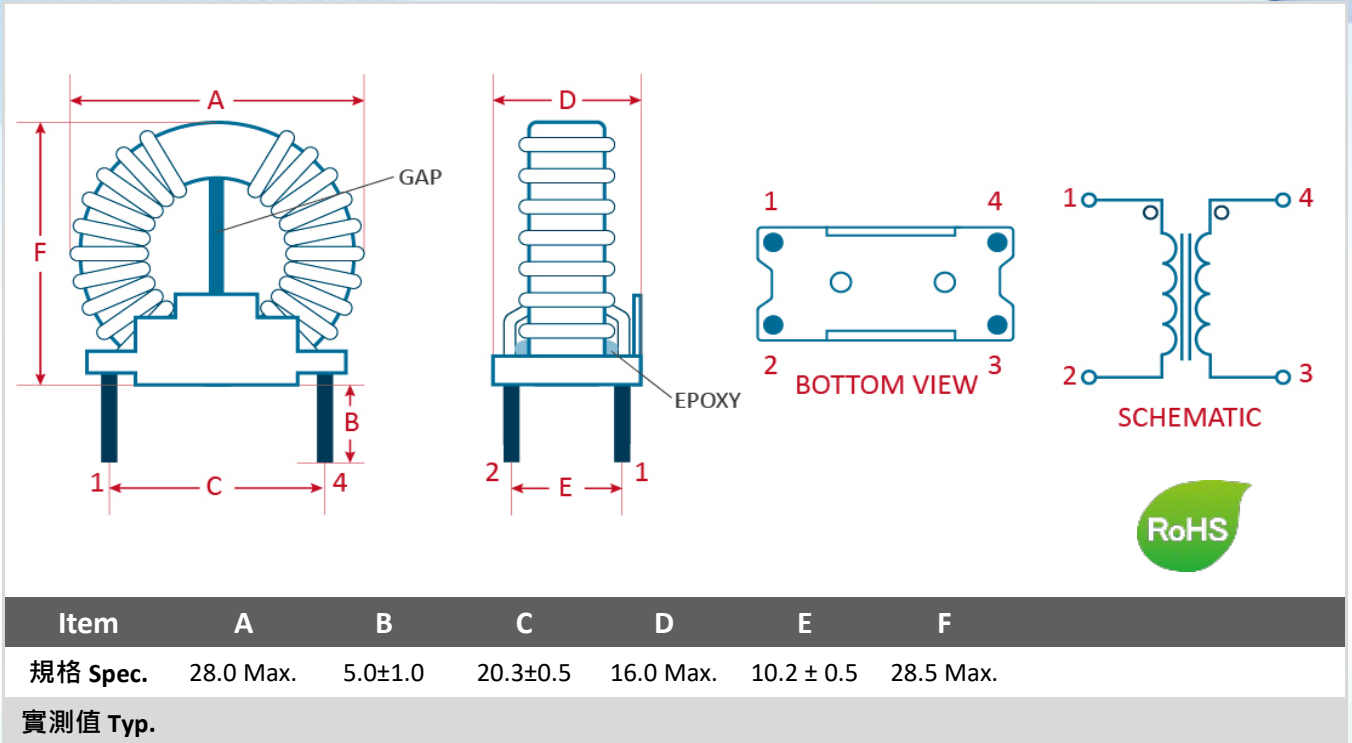

印字Marking : N/A

電特性要求 Electrical Characteristics :

Item	規格 Specifications	定義Note
<b>L1 = L2</b>	3.0mH Min	
<b>Test Freq</b>	@1KHz/ 0.25V	
<b>DCR1 = DCR2</b>	30 mΩ Max.	
<b>R.Current</b>	5A Max.	
<b>HI-POT TEST</b>	COILS - COILS	2KVAC / 1mA / 3sec
<b>TURNS</b>	25 Ts (REF.) X 2	
<b>Oper. Temp</b>	-25°C to +105°C	