

SPECIFICATION FOR APPROVED
樣品承認書

2022
 NEW

料號 P/N : LFT1264-20MH-0.5A-B

機構圖 Shape and Dimensions(mm) :

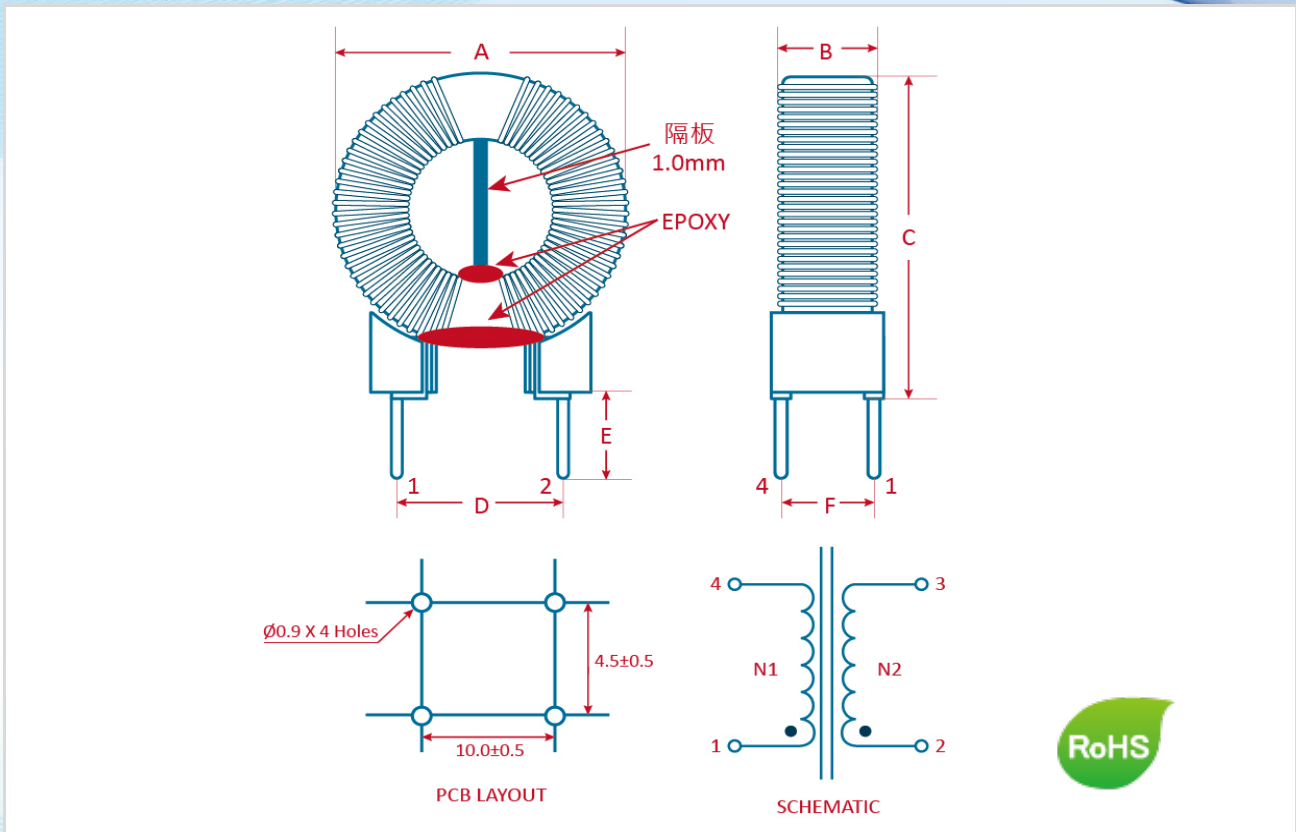

Item	A	B	C	D	E	F
規格 Spec.	16.5 Max.	9.0 Max.	18.0 Max.	10.0 ± 0.5	3.5 ± 0.5	4.5 ± 0.5
實測值 Typ.						

電特性要求 Electrical Characteristics :

Item	規格 Specifications	定義 Note
L1=L2	20 mH Min.	
Test Freq	@1KHz / 0.25V	
DCR1=DCR2	0.50Ω Max.	
R.Current	0.5 A Max.	
HI-POT TEST	COILS -- COILS AC500V / 5mA / 1s	
Turns	50Ts (Ref.) X2	
Wire	0.25Φmm 2UEWF	
Oper. Temp	-25°C to +85°C	