

SPECIFICATION FOR APPROVED
樣品承認書

2022
 NEW

料號 P/N : DP2111-651UH-8A-CSB

機構圖 Shape and Dimensions(mm) :

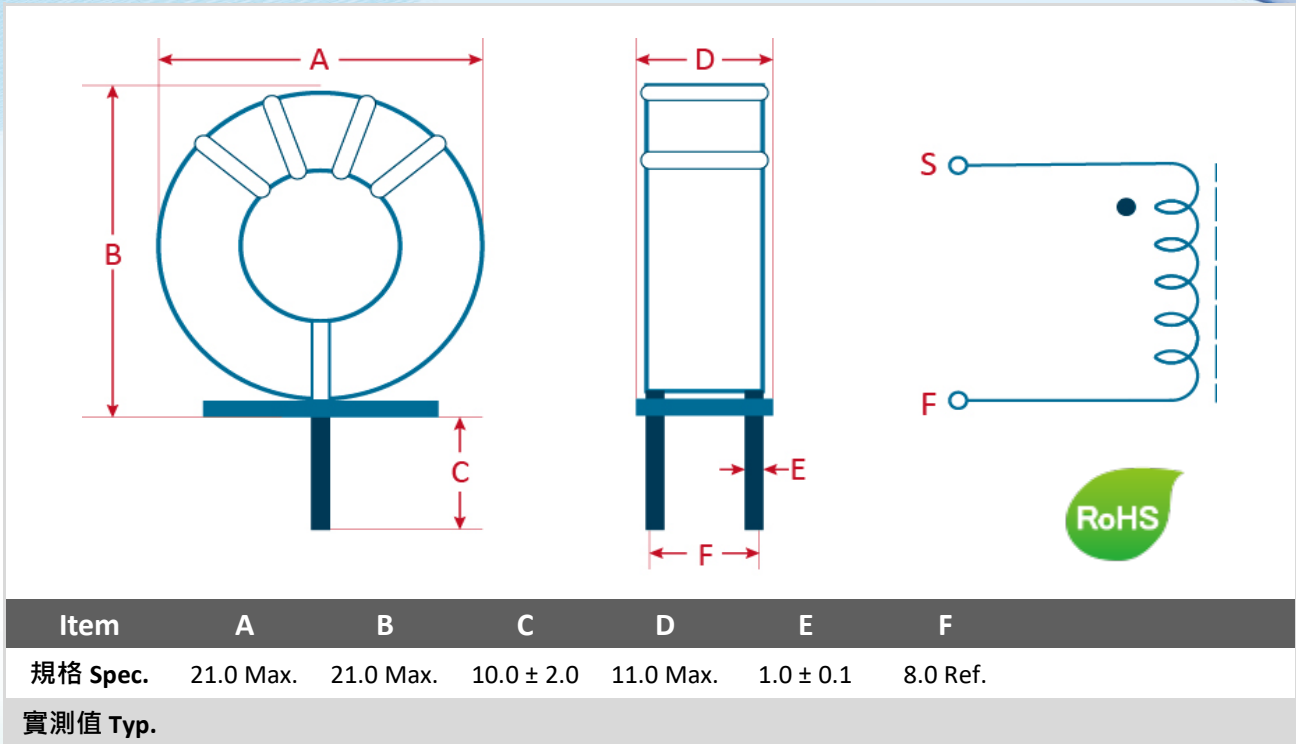

電特性要求 Electrical Characteristics :

Item	規格 Specifications	定義Note
L	650uH +80%	
Test Freq	@10KHz / 1V	
DCR	10mΩ Max.	
R.Current	8.0A Max.	
Turns	4.5Ts (Ref.)	
Oper. Temp	-40°C to +125°C	