

SPECIFICATION FOR APPROVED 樣品承認書

2023
NEW

料號 P/N : LFT1005-152U-5A-B

機構圖 Shape and Dimensions(mm):

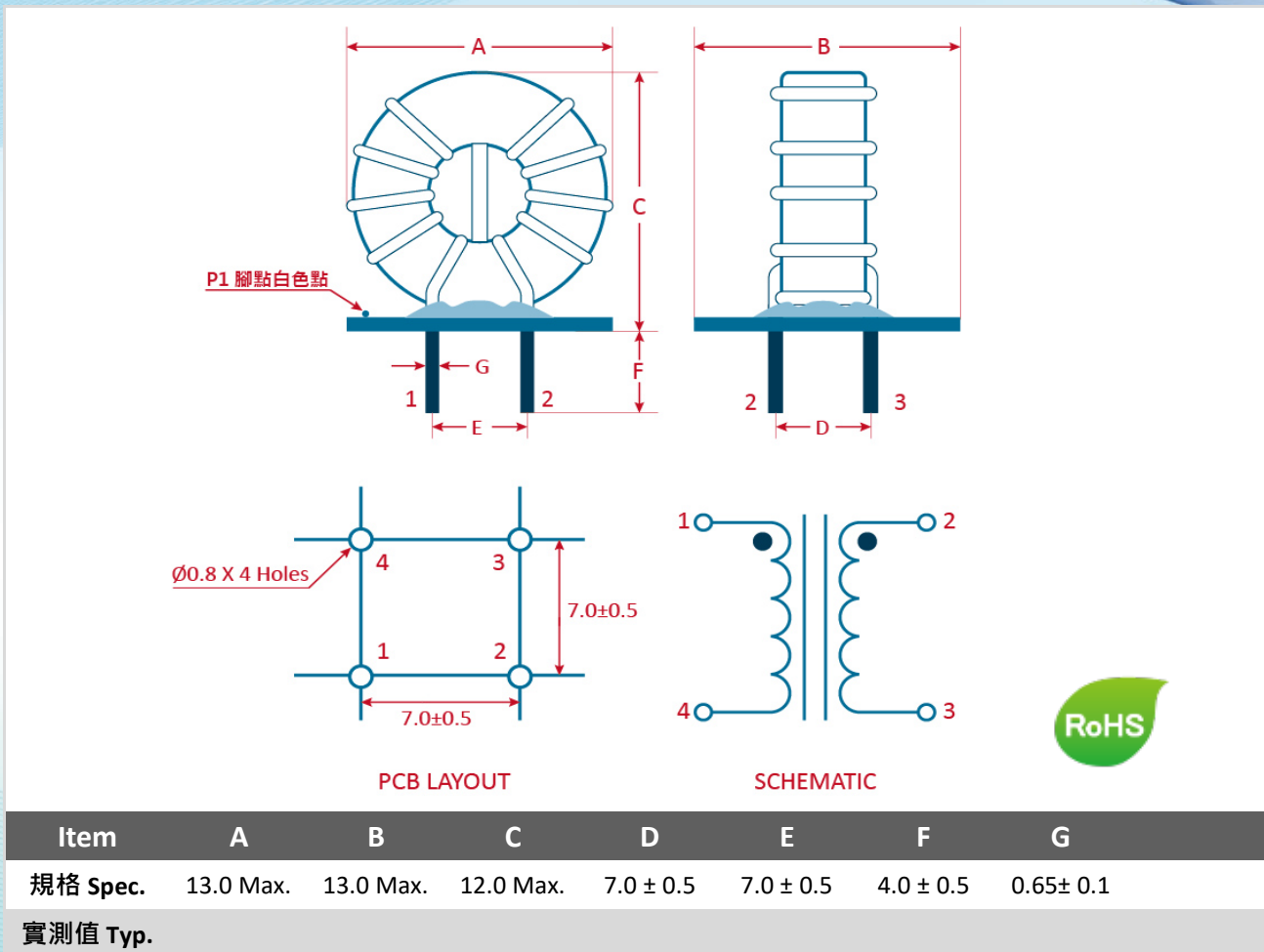

電特性要求 Electrical Characteristics :

Item	規格 Specifications	定義Note
L1-4=L2-3	1.5mH Min	
Test Freq	@10KHz / 1V	
DCR1-4=DCR2-3	50mΩ Max.	
R.Current	5A Max.	
Turns	6Ts (Ref.) X2	
Oper. Temp	-40°C to +125°C	