

SPECIFICATION FOR APPROVED 樣品承認書

2023
NEW

料號 P/N : DP5530-801L-12A-B

機構圖 Shape and Dimensions(mm) :

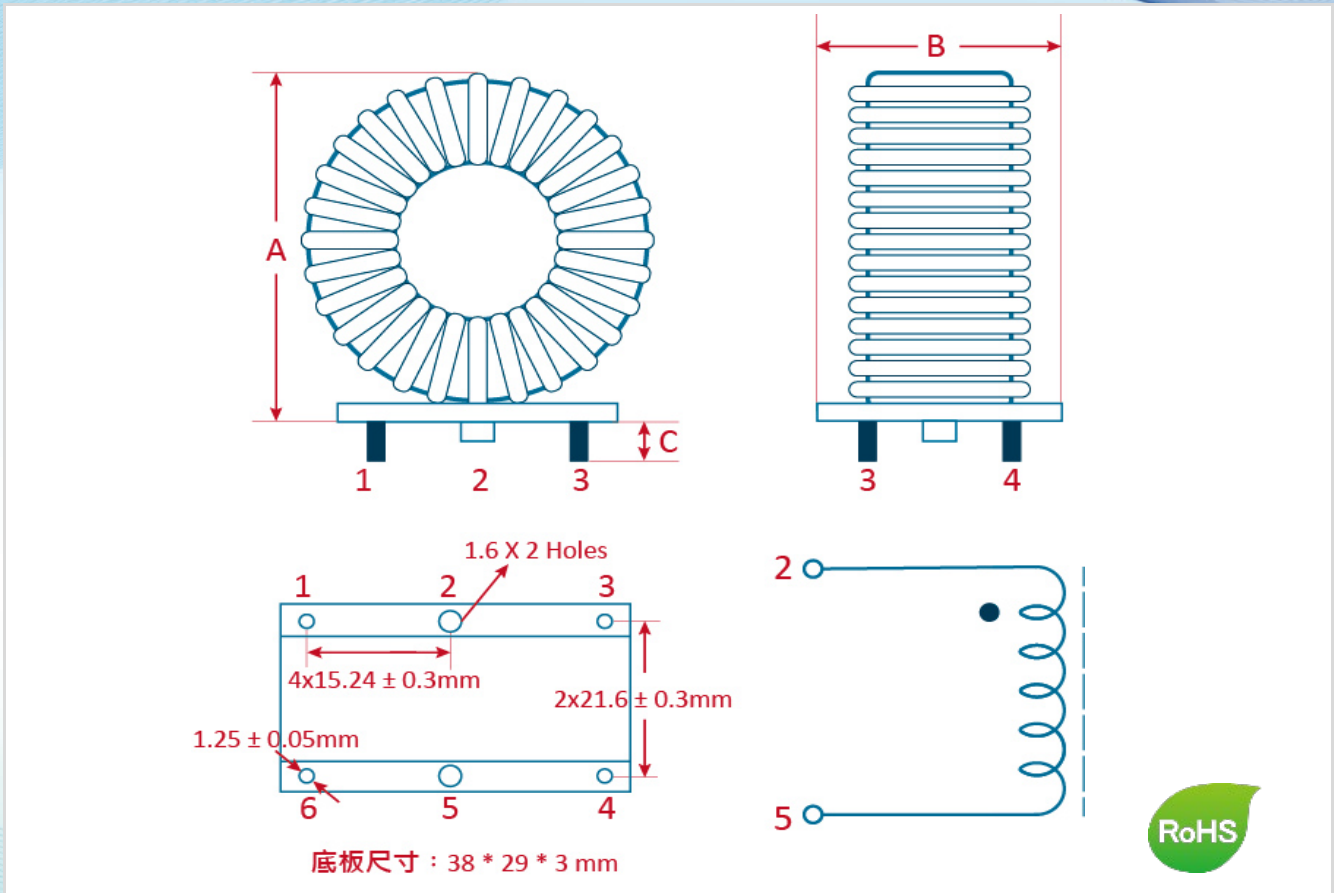

Item	A	B	C
規格 Spec.	55.0 MAX.	30.0 MAX.	4.0 ± 0.5
實測值 Typ.			

印字Marking : N/A

電特性要求 Electrical Characteristics :

Item	規格 Specifications	定義Note
L	800 uH ± 15%	
Test Freq	@1KHz/ 1.0V	
DCR2-5	80mΩ Max.	
R.Current	12A Max.	
HI-POT TEST	COIL - COIL	2KVAC / 5mA / 6sec
TURNS	70Ts (REF.)	
Oper. Temp	-20°C to +125°C	